

НАСОСЫ ДЛЯ ДЕСУЛЬФУРАЦИИ СЕРИИ TD/TDL



Архангельск (8182)63-90-72
Астана (7172)727-132
Астрахань (8512)99-46-04
Барнаул (3852)73-04-60
Белгород (4722)40-23-64
Брянск (4832)59-03-52
Владивосток (423)249-28-31
Волгоград (844)278-03-48
Вологда (8172)26-41-59
Воронеж (473)204-51-73
Екатеринбург (343)384-55-89
Иваново (4932)77-34-06

Ижевск (3412)26-03-58
Иркутск (395)279-98-46
Казань (843)206-01-48
Калининград (4012)72-03-81
Калуга (4842)92-23-67
Кемерово (3842)65-04-62
Киров (8332)68-02-04
Краснодар (861)203-40-90
Красноярск (391)204-63-61
Курск (4712)77-13-04
Липецк (4742)52-20-81

Киргизия (996)312-96-26-47

Магнитогорск (3519)55-03-13
Москва (495)268-04-70
Мурманск (8152)59-64-93
Набережные Челны (8552)20-53-41
Нижегород (831)429-08-12
Новокузнецк (3843)20-46-81
Новосибирск (383)227-86-73
Омск (3812)21-46-40
Орел (4862)44-53-42
Оренбург (3532)37-68-04
Пенза (8412)22-31-16

Россия (495)268-04-70

Пермь (342)205-81-47
Ростов-на-Дону (863)308-18-15
Рязань (4912)46-61-64
Самара (846)206-03-16
Санкт-Петербург (812)309-46-40
Саратов (845)249-38-78
Севастополь (8692)22-31-93
Симферополь (3652)67-13-56
Смоленск (4812)29-41-54
Сочи (862)225-72-31
Ставрополь (8652)20-65-13

Казахстан (772)734-952-31

Сургут (3462)77-98-35
Тверь (4822)63-31-35
Томск (3822)98-41-53
Тула (4872)74-02-29
Тюмень (3452)66-21-18
Ульяновск (8422)24-23-59
Уфа (347)229-48-12
Хабаровск (4212)92-98-04
Челябинск (351)202-03-61
Череповец (8202)49-02-64
Ярославль (4852)69-52-93

НАСОСЫ ДЛЯ ДЕСУЛЬФУРАЦИИ СЕРИИ TD/TDL



Product Description

Based on the successful design experience in manufacturing ZJ series slurry pumps and absorbed home and abroad advanced technology, we designs and manufactures DT and LT type pump, a special FGD engineering pump.

The max flow range can be up to 12000m³/h, the head is generally less than 100m. This type pump apply to all the desulfurization system, which can be used as a slurry circulating pump in large absorption tower and limestone slurry pump, gypsum slurry discharge pump, recycling pump, sump pump and so on.

Desulfurization Pump Features

- TD, TDL serial desulfurization pumps are developed elaborately based on advanced technology both here and abroad according to characteristics of pumps for flue gas desulfurization, Max. flux of the pumps can reach 12000m³/h, lift is typically less than 100m that covers all operating condition of pumps in the desulfurization system. The pump can be used as a serum circulating pump, a delivery pump of limestone serum, a discharge pump for plaster, a recovery pump and silo pump.
- The pump wet parts are designed by advanced CFD Flowing Simulating Analysis Techniques to ensure its design reliable and its working effective.
- It can change the impeller's position in pump casing by adjusting the bearing assembly to keep the pump working high efficiently all the time.
- This kind of pump adopts back pull-out structure, keeping it easy construction and easy maintenance. It doesn't need disassemble inlet & outlet pipeline.
- Two sets of taper roller bearing is fixed in the end of the pump, the column roller bearing is equipped at driving end. The bearing is lubricated by oil. All these can improve the bearing working condition and greatly enhance its life.

Working Condition

- It is used for large-scale slurry circulating pump of absorption tower, limestone slurry delivery pump, gypsum slurry discharge pump, recovery pump, sump pump, etc.

Structure Form

Series of DT FGD pump is a horizontal, single casing, single stage, single suction, pedestal or suspension structure pump.

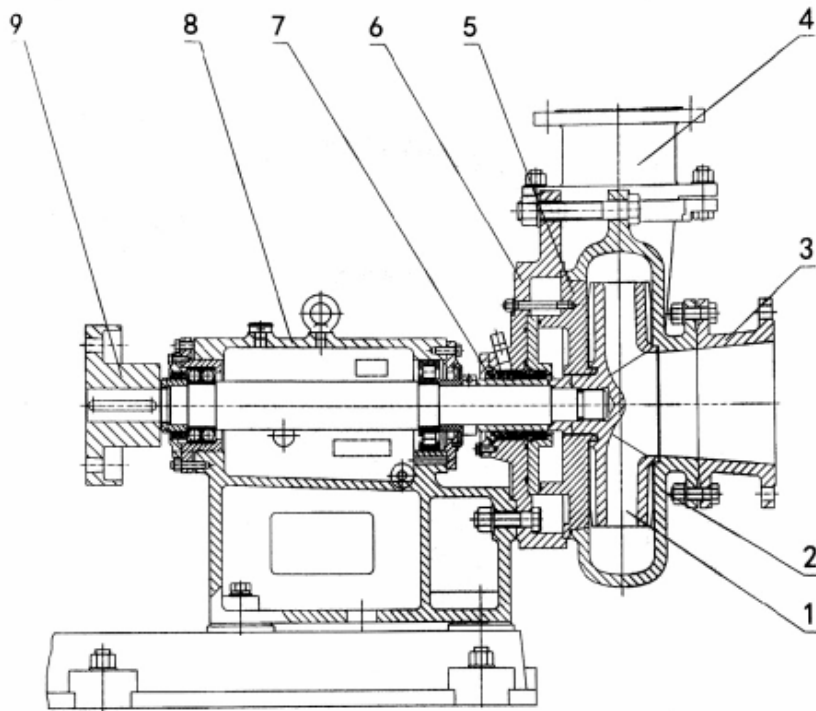

1	Impeller	5	Frame plate liner insert	9	Coupling
2	Volute liner	6	Stuffing box	10	Base plate
3	Suction short pipe	7	Mechanical seal		
4	Discharge short pipe	8	Frame		

Series of LT FGD pump is vertical, single casing pump. Adding suction pipe can meet the requirements of various operating conditions.

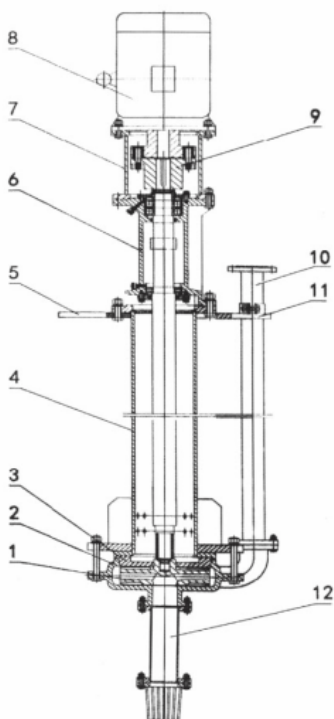

1	Impeller	7	Motor support
2	Volute liner	8	Motor
3	Frame plate liner insert	9	Coupling
4	Column	10	Discharge pipe
5	Left support plate	11	Right support plate
6	Bearing housing	12	Suction pipe

Technical Parameters (TD)

Pump Model	Allowable Max. Power (kw)	Clear Water Performance					Particle Max. Size Handled Occasionally (mm)	Pump Weight (kg)
		Capacity Q	Head H (m)	Speed n (r/min)	Max. Eff. (%)	(NPSH) r (m)		
		(m ³ /h)						
800TD-A90	900	4104-10690	7.8-27.8	400-595	86.4	4.3	88	7101
700TD-A90	900	3551-8988	10.0-33.8	400-595	86.7	5.6	68	6030
600TD-A82	500	1664-5600	5.2-27.8	300-595	88.3	2.2	152	4900
500TD-76	400	1555-3881	9.9-27.9	450-595	76.8	4.5	58	3512
400TD-65	400	1134-3330	8.8-31.1	490-472	80.1	5.2	60	3200
350TDL-A78	500	720-2865	11.6-51.1	400-720	78.0	3.5	104	3700
300TD-A60	400	574-2384	8.7-52.0	490-989	81.1	4.3	96	2790
250TD-A45	90	221-804	5.0-27.0	490-980	68.2	6.5	56	1321
200TDL-B45	90	136-639	5.5-30.1	490-990	80.8	2.0	51	1750
150TD-B55	132	139-630	11.3-53.7	490-990	78.1	2.3	56	1540
100TDL-A60	220	71-305	29.1-147.0	700-1480	57.9	2.4	18	890
100TD-A35	75	77-323	8.8-45.9	700-1480	73.2	1.9	42	550
80TD-A36	37	41-167	8.9-47.1	700-1480	62.4	1.5	16	480
65TDL-A40	55	34-159	11.5-60.1	700-1480	62.1	2.1	16	490
65TD-A30	22	21-99	7.0-35.6	700-1470	54.6	2.2	19	260
50TDL-B40	37	24.5-99.5	12.0-60.7	700-1470	55.0	3.1	14	490
50TD-A30	18.5	16-78	5.8-35.1	700-1460	48.5	0.8	16	210
40TDL-A25	45	16.8-74.7	13.7-88.6	1400-2950	42.5	2.6	9	185
40TD-A17	7.5	4.6-23.4	9.2-44.6	1400-2900	52.4	2.5	11	127
25TD-A25	4	4.7-19.9	3.3-21.6	700-1400	38.0	3.3	5	107
25TD-A15	5.5	4.4-19.3	6.2-34.4	1390-2900	41.8	1.3	8	89

Note:1.(NPSH)r:Value of the second speed.

2.Normal partical size: 56% of allowable occasional particle Max. size.



Архангельск (8182)63-90-72
Астана (7172)727-132
Астрахань (8512)99-46-04
Барнаул (3852)73-04-60
Белгород (4722)40-23-64
Брянск (4832)59-03-52
Владивосток (423)249-28-31
Волгоград (844)278-03-48
Вологда (8172)26-41-59
Воронеж (473)204-51-73
Екатеринбург (343)384-55-89
Иваново (4932)77-34-06

Ижевск (3412)26-03-58
Иркутск (395)279-98-46
Казань (843)206-01-48
Калининград (4012)72-03-81
Калуга (4842)92-23-67
Кемерово (3842)65-04-62
Киров (8332)68-02-04
Краснодар (861)203-40-90
Красноярск (391)204-63-61
Курск (4712)77-13-04
Липецк (4742)52-20-81

Киргизия (996)312-96-26-47

Магнитогорск (3519)55-03-13
Москва (495)268-04-70
Мурманск (8152)59-64-93
Набережные Челны (8552)20-53-41
Нижегород (831)429-08-12
Новокузнецк (3843)20-46-81
Новосибирск (383)227-86-73
Омск (3812)21-46-40
Орел (4862)44-53-42
Оренбург (3532)37-68-04
Пенза (8412)22-31-16

Россия (495)268-04-70

Пермь (342)205-81-47
Ростов-на-Дону (863)308-18-15
Рязань (4912)46-61-64
Самара (846)206-03-16
Санкт-Петербург (812)309-46-40
Саратов (845)249-38-78
Севастополь (8692)22-31-93
Симферополь (3652)67-13-56
Смоленск (4812)29-41-54
Сочи (862)225-72-31
Ставрополь (8652)20-65-13

Казахстан (772)734-952-31

Сургут (3462)77-98-35
Тверь (4822)63-31-35
Томск (3822)98-41-53
Тула (4872)74-02-29
Тюмень (3452)66-21-18
Ульяновск (8422)24-23-59
Уфа (347)229-48-12
Хабаровск (4212)92-98-04
Челябинск (351)202-03-61
Череповец (8202)49-02-64
Ярославль (4852)69-52-93